

## TECHNICAL DATASHEET

### Absolute Encoders AD 36



- For brushless servo motors
- Resolver size 15 compatible
- Through hollow shaft 8 mm
- 19 Bit Singleturn + 12 Bit Multiturn
- +120°C operating temperature
- 10,000 rpm continuous operation
- Optical encoder with a true geared multiturn
- BiSS or SSI interface
- Sinewave 1 Vpp
- Bandwidth 500 kHz



#### GENERAL INFORMATION

The AD36 is an absolute encoder with a true geared Multiturn, optical sensing technology and 36 mm diameter. Unique is the through hollow shaft which enables an assembly that is compatible with resolver size 15. The mechanical design consists of two ball bearings and a flexible torque support. The AD36 complements the **ACURO-DRIVE** series and is appropriate for use within BLDC servo motors with small frame sizes.

#### Fully digital control loop

The new and completely digital OptoAsic technology enables the transition to a truly digital drive system. The conventional absolute encoders still have analog sine wave signals for the feedback of speed and position data. The AD36, however, provides fully digital position data up to 19 Bit (Singleturn) and 12 Bit (Multiturn) over the BiSS interface with a variable clock rate up to 10 MHz. BiSS is the only open high speed bidirectional sensor interface available on the market. Backward compatibility to most of the existing drives is realized through the variant with SSI interface together with 2048 sine –cosine periods per revolution.

#### Integrated diagnostic system

The AD36 has an integrated diagnostic system that controls and regulates the internal signals. Maximum motor uptime is achieved through the pre warning in case of any system error or aging effects well before they affect the function of the encoder. A code plausibility check guarantees that the output data represents always the true position. Also the operating temperature can be measured and read out with 8 Bit resolution. If programmable limits are exceeded or under run this is indicated over warn and alarm bits.

#### TECHNICAL DATA mechanical

Housing diameter	37.5 mm
Shaft diameter	8 mm (Through hollow shaft) 8 mm (Hubshaft)
Flange (Mounting of housing)	Tether
Protection class shaft input (EN 60529)	IP40
Protection class housing (EN 60529)	IP40
Axial endplay of mounting shaft (hubshaft)	± 0.5 mm
Radial runout of mating shaft (hubshaft)	± 0.05 mm
Max. speed	max. 10 000 rpm (continuous), max. 12 000 rpm (short term)

## TECHNICAL DATASHEET

### Absolute Encoders AD 36

#### TECHNICAL DATA mechanical (continued)

Torque	0.01 Ncm
Moment of inertia	ca. $2.5 \times 10^{-6}$ kgm <sup>2</sup>
Vibration resistance (DIN EN 60068-2-6)	100 m/s <sup>2</sup> (10 ... 2000 Hz)
Shock resistance (DIN EN 60068-2-27)	1000 m/s <sup>2</sup> (6 ms)
Operating temperature	-15 °C ... +120 °C
Storage temperature <sup>1</sup>	-15 °C ... +85 °C
Weight	approx. 80 g (ST) / 130 g (MT)
Connection	Cable, radial PCB connector, 12 pole

<sup>1</sup> due to packing

#### TECHNICAL DATA electrical

Supply voltage	DC 5 V -5 %/+10 % or DC 7 - 30 V
Max. current w/o load	50 mA (ST), 100 mA (MT)
Resolution singleturn	12 - 19 Bit (BiSS) 12 - 17 Bit (SSI)
Resolution multiturn	12 Bit
Output code	Gray
Drives	Clock and Data / RS422
Incremental signals optional	Sinus-Cosinus 1 Vpp
Number of pulses	2048
3dB limiting frequency	500 kHz
Absolute accuracy	±35"
Repeatability	±7"
Alarm output	Alarm bit (SSI Option), warning and alarm bit (BiSS)

#### ELECTRICAL CONNECTIONS PCB connector, 12 pole

Color	PIN	Signals
grey	1a	$\overline{\text{Data}}$
white/green	2a	A +
black	3a	0 V Sensor
red/blue	4a	B +
green	5a	$\overline{\text{Clock}}$
violet	6a	5 V Sensor
white	1b	DC 5 V/ 7 - 30 V
yellow	2b	Clock
grey/pink	3b	B -
brown	4b	0 V (U <sub>N</sub> )
brown/green	5b	A -
pink	6b	Data

## TECHNICAL DATASHEET

### Absolute Encoders AD 36

#### CONNECTION ENCODER SIDE

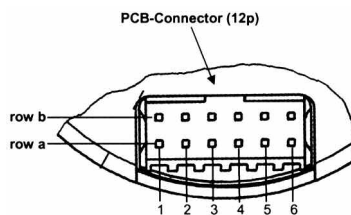

12 pin PCB connector  
manufacture Berg, type Minitek

#### DIMENSIONED DRAWINGS

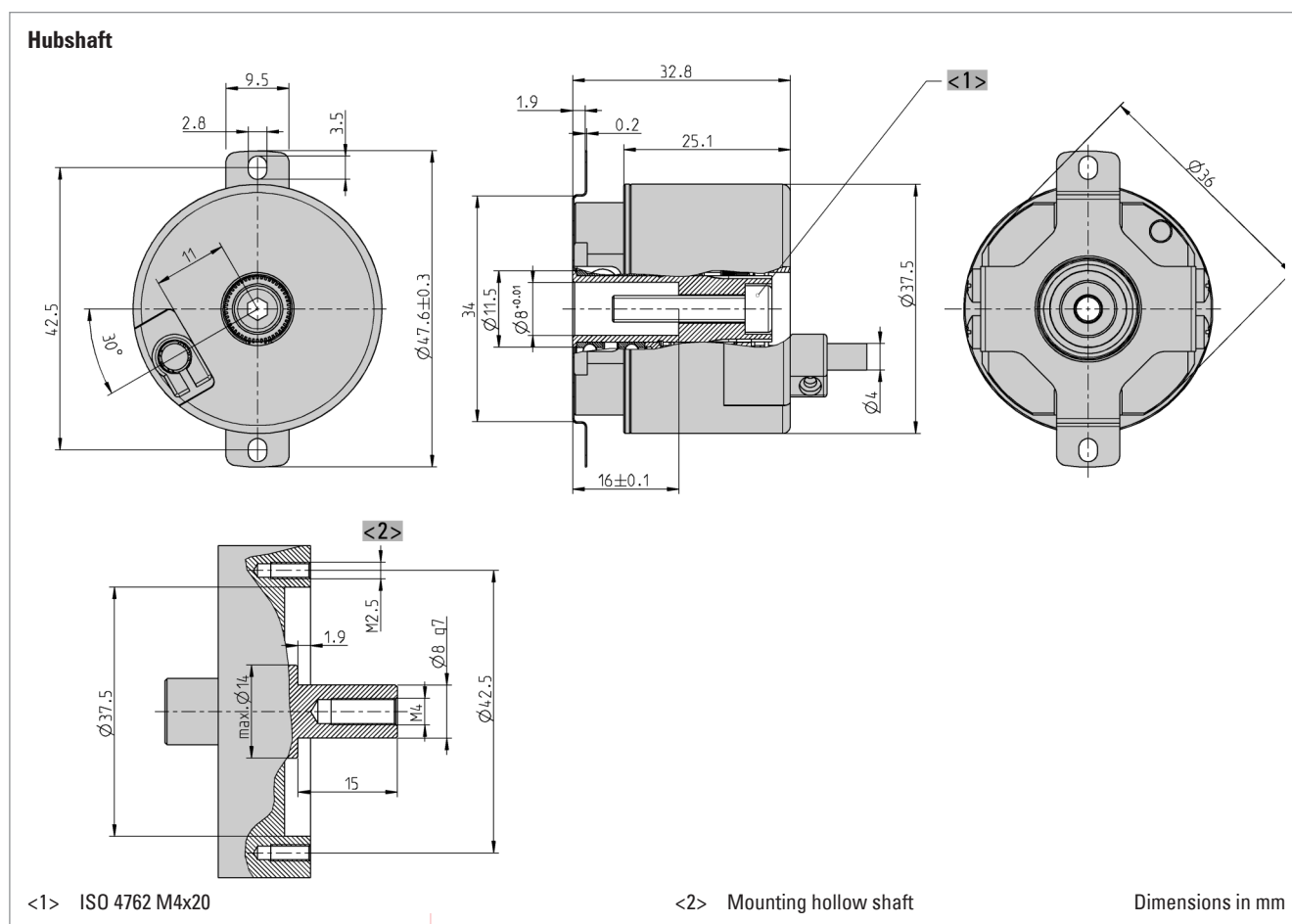

## TECHNICAL DATASHEET

### Absolute Encoders AD 36

#### DIMENSIONED DRAWINGS (continued)

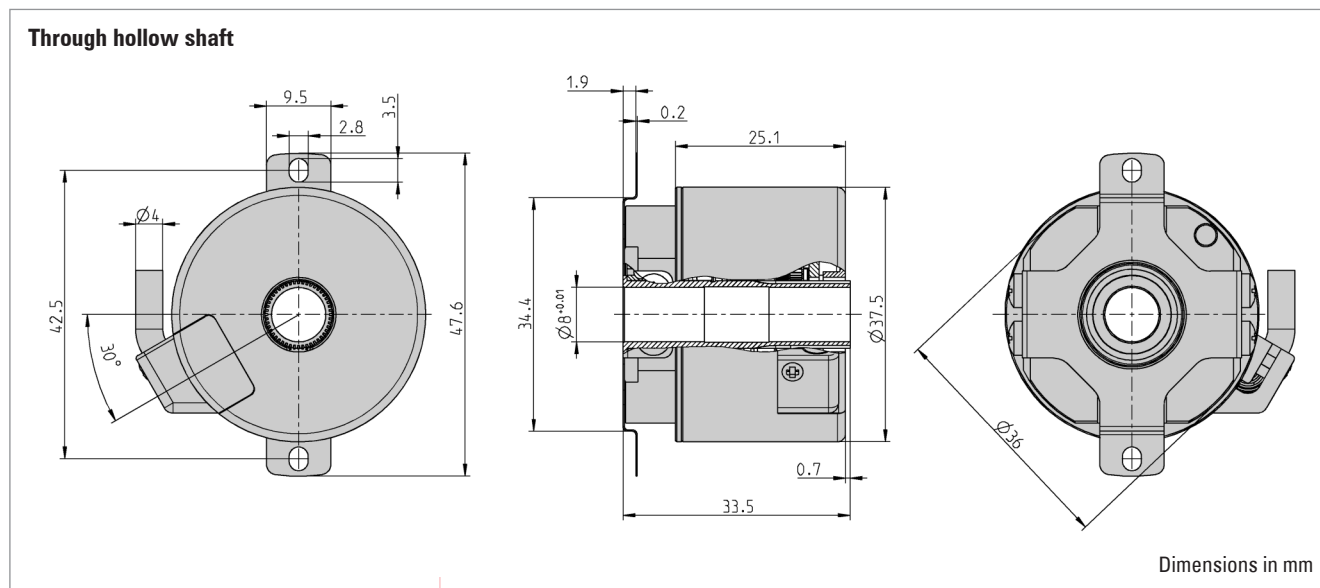

#### ORDERING INFORMATION

Type	Resolution	Supply voltage	Flange, Protection, Shaft	Interface	Connection
<input type="checkbox"/>	<input type="text"/>	<input type="checkbox"/>	<input type="checkbox"/>	<input type="checkbox"/>	<input type="checkbox"/>
<b>AD36</b>	<b>0012</b> 12 Bit ST <b>0013</b> 13 Bit ST <b>0014</b> 14 Bit ST <b>0017</b> 17 Bit ST <b>0019</b> 19 Bit ST (BiSS) <b>1213</b> 12 Bit MT + 13 Bit ST <b>1217</b> 12 Bit MT + 17 Bit ST <b>1219</b> 12 Bit MT + 19 Bit ST (BiSS)	<b>A</b> DC 5 V <b>E</b> DC 7 - 30 V	<b>F.0C</b> Spring tether, IP40, 8 mm trough hollow shaft <b>F.0R</b> Spring tether, IP40, 8 mm hub shaft	<b>BI</b> BiSS <b>SC</b> SSI Gray (+SinCos 1Vpp)	<b>O</b> PCB connector, 12 pole <b>B</b> PCB connector, 12 pole, with mating connector and 0.5 m cable

**TECHNICAL DATASHEET****Absolute Encoders AD 36  
Accessories**

DISPLAYS

Position indicator Signo-SSI

**Ordering code**

0 727 111